

Microwave Journal



Affordable Real-Time Spectrum Analysis

Signal Hound
La Center, WA

Signal Hound's latest innovation is the BB60C spectrum analyzer, an enhanced version of its well-received predecessor, the BB60A. The Signal Hound BB60C has improved SFDR by typically 20 dB, flattened the noise floor by reducing frequency band transitions more than 8 dB, extended the operating temperature down to -40°C and up to $+65^{\circ}\text{C}$, and expanded the streaming I/Q bandwidth to make it selectable from 250 kHz to 27 MHz. With a price point under \$3K, the BB60C is a compelling choice for a broad range of applications.

HARDWARE

The Signal Hound BB60C is a two-stage superheterodyne receiver, using two independent intermediate frequencies (IF). Each IF has a corresponding distributed element notch filter in the RF section, yielding excellent IF rejection. Each RF band also has a distributed element filter buried in the multilayer PCB laminate, specifically engineered to reject that band's image frequencies and reduce LO feed-through (see **Figure 1**).

To reduce spurious signals from second-order intermodulation where filtering was not practical, push-pull amplifiers were used in both the preamplifier and mixer stages, effectively canceling even-order mixing products. Direct conversion was used below 20 MHz, avoiding the intermodulation products associated with mixing.

Gain control is achieved in the BB60C using the front end attenuator and preamplifier. The front end was designed to provide good spurious-free dynamic range (SFDR) at any reference level.

The Cypress FX3 USB 3.0 peripheral controller enables the BB60C to continuously stream 80 million 14-bit ADC samples per second to a PC or laptop for processing.

SOFTWARE

The Signal Hound BB60C includes an open-source Windows-based spectrum analyzer software application. The software has traditional controls such as frequency span/center/start/stop, resolution bandwidth, video bandwidth, reference level, configurable traces and markers. Using OpenGL to leverage the GPU acceleration of modern computer graphics, rich display features such as 2D and 3D spectrogram plots and a real-time color persistence display format were added to enhance the user experience and simplify signal identification.

The BB60C ships with a fully documented application programming interface (API) written in C/C++. This provides a tool for users to create their own custom software applications to harness the full capabilities of the BB60C, including record on event trigger, real-time analysis and streaming I/Q data. Programmers can either customize the existing open-source

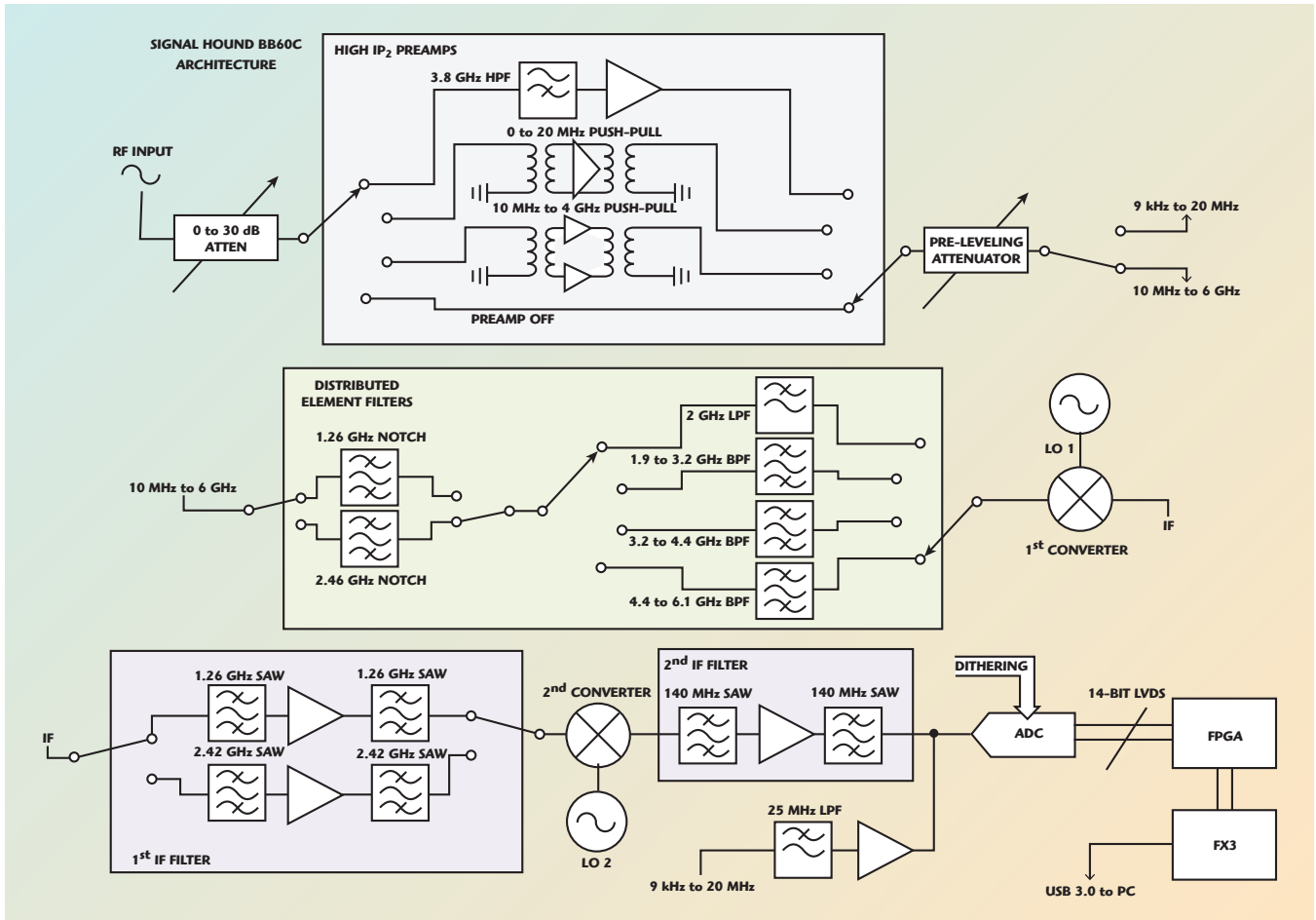

▲ Fig. 1 BB60C system architecture.

application or develop a targeted application from scratch.

The BB60C can be used as an RF recorder by either recording and playing back sweeps, or recording streaming I/Q data directly using the API. The API now features amplitude- and frequency-corrected I/Q data with adjustable sample rates and bandwidth, to support everything from streaming the full 27 MHz of spectrum, to sending a single 250 kHz channel across the Internet.

TRUE REAL-TIME SPECTRUM ANALYSIS

Gapless spectrum coverage, the hallmark of real-time spectrum analysis, is achieved for the entire 27 MHz of Instantaneous Bandwidth (IBW) by using 75 percent overlapping Fast Fourier Transforms (FFT). This means that every digitized sample will be included in 4 FFTs. In this mode, any signal inside the IBW of sufficient amplitude, regardless of duration, will show up in the display. For maximum displayed amplitude, a signal must be

TABLE I SIGNAL HOUND BB60C ABBREVIATED SPECIFICATIONS (PRELIMINARY)	
Frequency Range	9 kHz to 6 GHz
Amplitude Range	+10 dBm to DANL
Amplitude Accuracy	±2.0 dB
Sweep Speed (RBW ≥ 10 kHz)	24 GHz/sec
Streaming Real-Time Bandwidth (Ampl Corrected)	250 kHz to 27 MHz selectable
Displayed Average Noise Level	-159 dBm/Hz + 1 dB/GHz (500 kHz to 6 GHz)
Residual and Spurious Responses	-50 dBc (Ref. Level -50 to +10 dBm, signal 10 dB below ref Level)
SSB Phase Noise	-84 dBc/Hz (1 GHz center freq with 10 kHz offset)
Operating Temperature	0° to +65°C (std.), or -40° to +65°C (option-1)

present for one entire FFT. For a 631 kHz resolution bandwidth, this works out to about 4 microseconds, but even a 1 microsecond pulse will be attenuated by only 2 to 3 dB.

Advances in Single Instruction Multiple Data (SIMD) instructions have enabled modern processors, such as Intel's Core i7, to perform signal processing at a very high rate, often in excess of 100 GFLOPS. By lever-

aging Intel's Integrated Performance Primitives, this power has been harnessed with the BB60C. Even when the API is shoving 320 million data points per second into FFTs, or converting streaming IF into amplitude- and frequency-corrected I/Q data, the BB60C only uses a modest fraction of available processor resources. See **Table 1** for a summary of the specifications.

ProductFeature

UNIQUE FEATURES

The Signal Hound BB60C is USB-powered, eliminating the need for external power supplies. This is a convenience for bench-top users, but a must in the field. During manufacture, each BB60C is tested in an environmental temperature chamber. Amplitude readings across frequency, gain and attenuation are measured to generate correction coefficients in 10°C steps, which are then saved in the BB60C flash memory. The API uses this data, along with the BB60C's internal temperature sensor, to compensate amplitude readings for actual operating conditions. This ensures that full accuracy measurements can be taken anywhere from Antarctica to the Sahara. The standard temperature range is built to operate from 0° to +65°C, and the option-1 extended temperature range is built to operate from -40° to +65°C.

In addition to the timebase 10 MHz in/out, the BB60C provides a trigger in/out. The trigger-in mode flags the data sample in the I/Q stream corresponding to the trigger's rising (or falling) edge. The API corrects for the propagation delay through the analog and digital filters, enabling high precision timing, such as time-gated sweeps or GPS time-stamping. The BB60C is built to stock. It generally ships within one day after receiving an order, making it an ideal solution for time-sensitive jobs, when waiting on a manufacturer's standard lead time is not an option.

APPLICATIONS

The Signal Hound BB60C is well suited to several applications due to its real-time analysis capability. Some key

examples include intermittent interference hunting, spread spectrum signal analysis, process automation, and remote spectrum monitoring.

Intermittent interference hunting poses several challenges. A traditional spectrum analyzer will only display interference if it occurs within the RBW being measured, making interference difficult to identify and quantify. A real-time spectrum analyzer like the BB60C processes thousands of RBWs simultaneously (in parallel), making the task of interference hunting easy.

Identifying and analyzing frequency hopping spread spectrum signals can pose a challenge for a traditional spectrum analyzer, which will only catch a small fraction of hops. The BB60C's ability to simultaneously stream the entire 902 to 928 MHz ISM band, or sweep from 2400 to 2475 MHz in about 4 ms, greatly simplifies this process.

Production line automation and remote spectrum monitoring can be accomplished over an Ethernet connection with the combination of a BB60C, custom software written using the API, and an Intel vPro enabled PC such as the NUC, model DC53427HYE. Intel vPro technology makes it possible to remotely turn on or off the PC, perform a system recovery if the PC or BB60C crashes, and manage software updates.

**Signal Hound,
La Center, WA
(800) 260-TEST or
001-360-263-5006,
sales@signalhound.com,
www.signalhound.com/MWJ.**